

**Bereznyak-Isayev BI-1**  
by Ora Lassila © 1997, 2019  
sheet 1 of 1

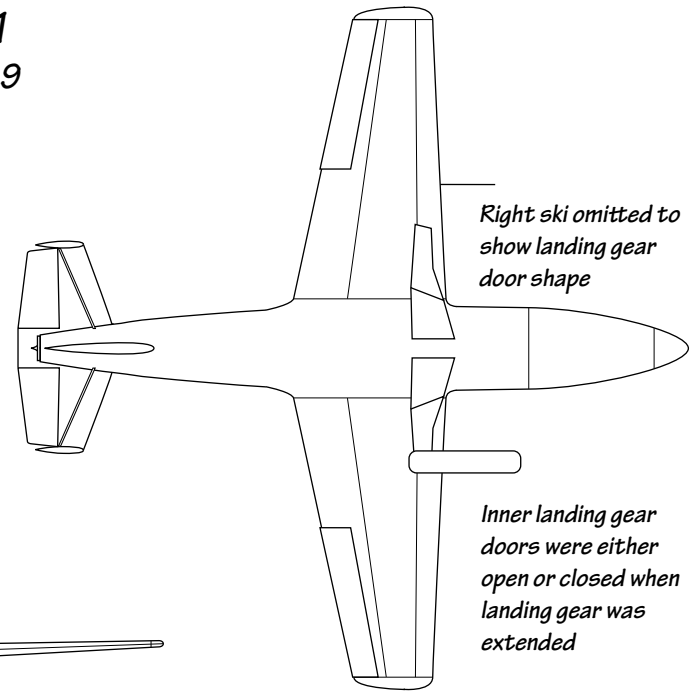

Right ski omitted to show landing gear door shape

Inner landing gear doors were either open or closed when landing gear was extended

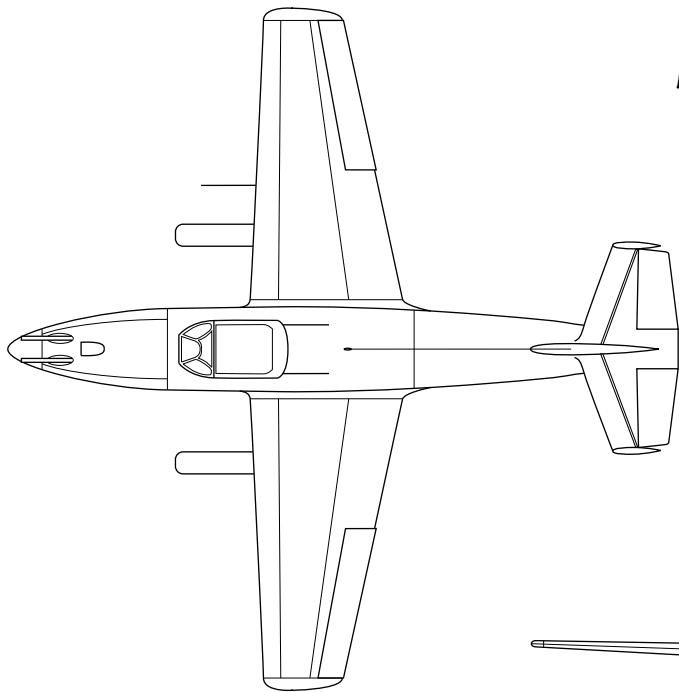
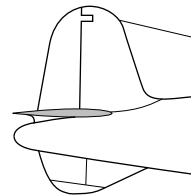
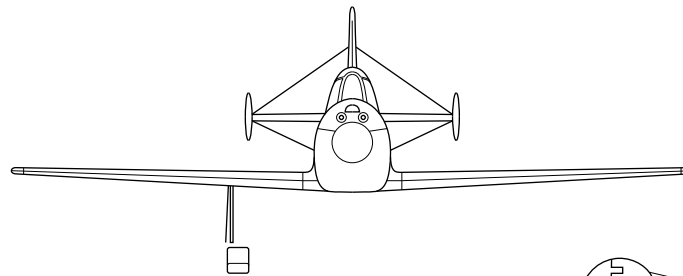

Tailpipe fairing used on the first prototype (glider). Please note that this version did not have the tailplane struts which were later added to the powered version.

The Bereznyak-Isayev BI-1 was the first Russian rocket-powered fighter. It first flew (under rocket power) on May 15th, 1942. Unless otherwise stated, these plans depict the third prototype configuration in 1942.

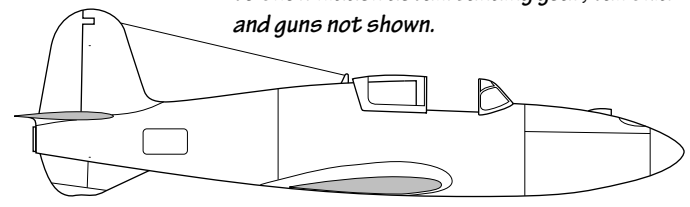
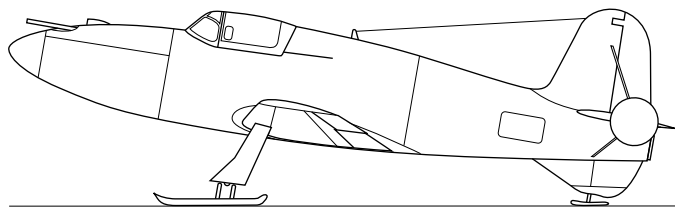

Wing, small vertical fins and struts removed to show hidden detail. Landing gear, tail skid and guns not shown.